

ComfoAir 200 Installer manual

zehnder

always
around you

Heating

Cooling

Fresh Air

Clean Air



All rights reserved.

This manual has been compiled with the utmost care. The publisher cannot be held liable for any damage caused as a result of missing or incorrect information in this manual. In case of disputes the Dutch version of these instructions will be binding.

Table of Contents

Preface	1
1 INTRODUCTION.....	1
1.1 Warranty and liability	1
1.1.1 Guarantee conditions	1
1.1.2 Liability	1
1.2 Safety	2
1.2.1 Safety regulations.....	2
1.2.2 Safety provisions and measures.....	2
1.2.3 Pictograms used.....	2
2 FOR THE FITTER	3
2.1 ComfoAir configuration.....	3
2.2 Technical specifications.....	4
2.3 Dimension sketch	6
2.4 Installation conditions	7
2.5 Installation of the ComfoAir	7
2.5.1 Transport and unpacking	7
2.5.2 Checking the delivery.....	7
2.6 Mounting of the ComfoAir	7
2.6.1 Mounting on the ceiling.....	7
2.6.2 Mounting on the wall	8
2.6.3 Connection of the air ducts.....	8
2.6.4 Connection of the condensation drain	9
2.7 Commissioning the ComfoAir	9
2.7.1 Display on the unit.....	10
2.7.2 P menus for the installer	11
2.8 Programming air specifications	15
2.9 Maintenance by the installer	16
2.9.1 Inspecting and cleaning the heat exchanger	16
2.9.2 Inspecting and cleaning the fans.....	17
2.10 Malfunctions.....	17
2.10.1 Malfunction alerts on the digital operating device	17
2.10.2 3-position switch with malfunction indicator	18
2.10.3 What to do in the event of a malfunction / Troubleshooting	19
2.10.4 Malfunctions (or problems) without alerts.....	29
2.11 Service parts.....	30
2.12 Wiring diagram: ComfoAir 200 Basic – LEFT-HAND version.....	31
2.13 Wiring diagram: ComfoAir 200 Basic – RIGHT-HAND version	32
2.14 Wiring diagram: ComfoAir 200 Luxe – LEFT-HAND version.....	33
2.15 Wiring diagram: ComfoAir 200 Luxe – RIGHT-HAND version.....	34
2.16 EEC declaration of conformity.....	35

Preface



Carefully read this manual before use.

This manual provides all the information required for safe and optimal installation and maintenance of the ComfoAir 200. It is also intended as a reference for servicing, so that this can be carried out in a responsible manner. The device is subject to continuous development and improvement. As a result, the ComfoAir 200 may slightly differ from the descriptions.

1 Introduction

The device's name is ComfoAir 200. In the following it will be referred to as ComfoAir.

The ComfoAir is a balanced ventilation system with heat recovery in order to create healthy, balanced and energy-efficient ventilation in houses. The ComfoAir has a CE marking on the identification plate. The identification plate can be found on top of the ComfoAir.

1.1 Warranty and liability

1.1.1 Guarantee conditions

The ComfoAir is covered by a manufacturer's warranty for a period of 24 months after fitting up to a maximum of 30 months after the date of manufacture. Warranty claims may only be submitted for material faults and/or construction faults arising during the warranty period. In the case of a warranty claim, the ComfoAir must not be dismantled without written permission from the manufacturer. Spare parts are only covered by guarantee, if they were supplied by the manufacturer and have been installed by an approved installer.

The warranty becomes invalid if:

- The guarantee period has elapsed;
- The device is used without filters;
- Parts are used that have not been supplied by the manufacturer;
- Non-authorized changes or modifications have been made to the unit.

1.1.2 Liability

The ComfoAir has been designed and manufactured for use in balanced ventilation systems incorporating Zehnder heat recovery systems. Any other application is seen as inappropriate use and can result in damage to the ComfoAir or personal injury, for which the manufacturer cannot be held liable.

The manufacturer is not liable for any damage originating from:

- Non-compliance with the safety, operating and maintenance instructions in this manual;
- The use of components not supplied or recommended by the manufacturer.
Responsibility for the use of such components lies entirely with the installer;
- Normal wear and tear.

1.2 Safety

1.2.1 Safety regulations

Always comply with safety regulations in this manual. Non-compliance with the safety regulations, warnings, notes and instructions in this manual can cause personal injury or damage to the ComfoAir.

- The ComfoAir may only be installed, connected, rendered operational and maintained by an appropriately approved installer, unless otherwise indicated in this manual;
- Installation of the ComfoAir must be carried out in accordance with the general and locally applicable construction, safety and installation instructions of the local council, electricity and water boards or other agencies;
- Observe the safety regulations, warnings, comments and instructions as prescribed in this manual at all times;
- Keep this manual with the ComfoAir throughout its life;
- Instructions with regard to cleaning or replacing the filters of the intake and exhaust valves must be carefully observed;
- The specifications stated in this document may not be changed;
- Modifying the ComfoAir is not allowed;
- The ComfoAir is only suitable for connection to 230V 50Hz mains;
- It is recommended to take out a maintenance contract so that the device is checked on a regular basis. The supplier can provide a list of registered installers nearby.

1.2.2 Safety provisions and measures

- The ComfoAir cannot be opened without using tools;
- It should not be possible to touch the fans, therefore ducting must be connected to the ComfoAir at a minimum duct length of 900mm.

1.2.3 Pictograms used

The following pictograms are used in this manual:



Point of attention.



Risk of:

- ***damage to the device;***
- ***performance of the device is compromised if instructions are not observed carefully.***



Risk of personal injury for the user or installer.

2 For the Fitter

2.1 ComfoAir configuration

The standard ComfoAir configuration consists of:

- External casing (A) of coated sheeting;
- Interior (B) of high-quality, expanded polypropylene EPP;
- 4 connections (C) for the air ducts;
- 2 plate filters (D) for air purification. Filter classification: outside air G4, return air G4;
- 2 energy-efficient DC motors (E) with high-efficient fan;
- HE (High efficient) heat exchanger (F);
- Display (G) to read data, and for programming procedures (optional);
- Control circuit board (H) with connections for the fans, the bypass, the Pre heater, temperature sensors (T1 to T4), the 3-position switch with or without malfunction indicator (optional) and the bathroom switch (optional);
- Connector panel (I) with all the extra connections of the ComfoAir Luxe;
- Identification plate (l) detailing information on the ComfoAir (not visible);
- Condensation drain (J) to drain the condensation of the warm return air;
- Sticker (K) detailing the air connections (not visible);
- Cable for power supply (not visible);
- 2 Filtercaps (M);
- 4 Ceiling mounting brackets (N) or 1 Wall mounting bracket (not visible).

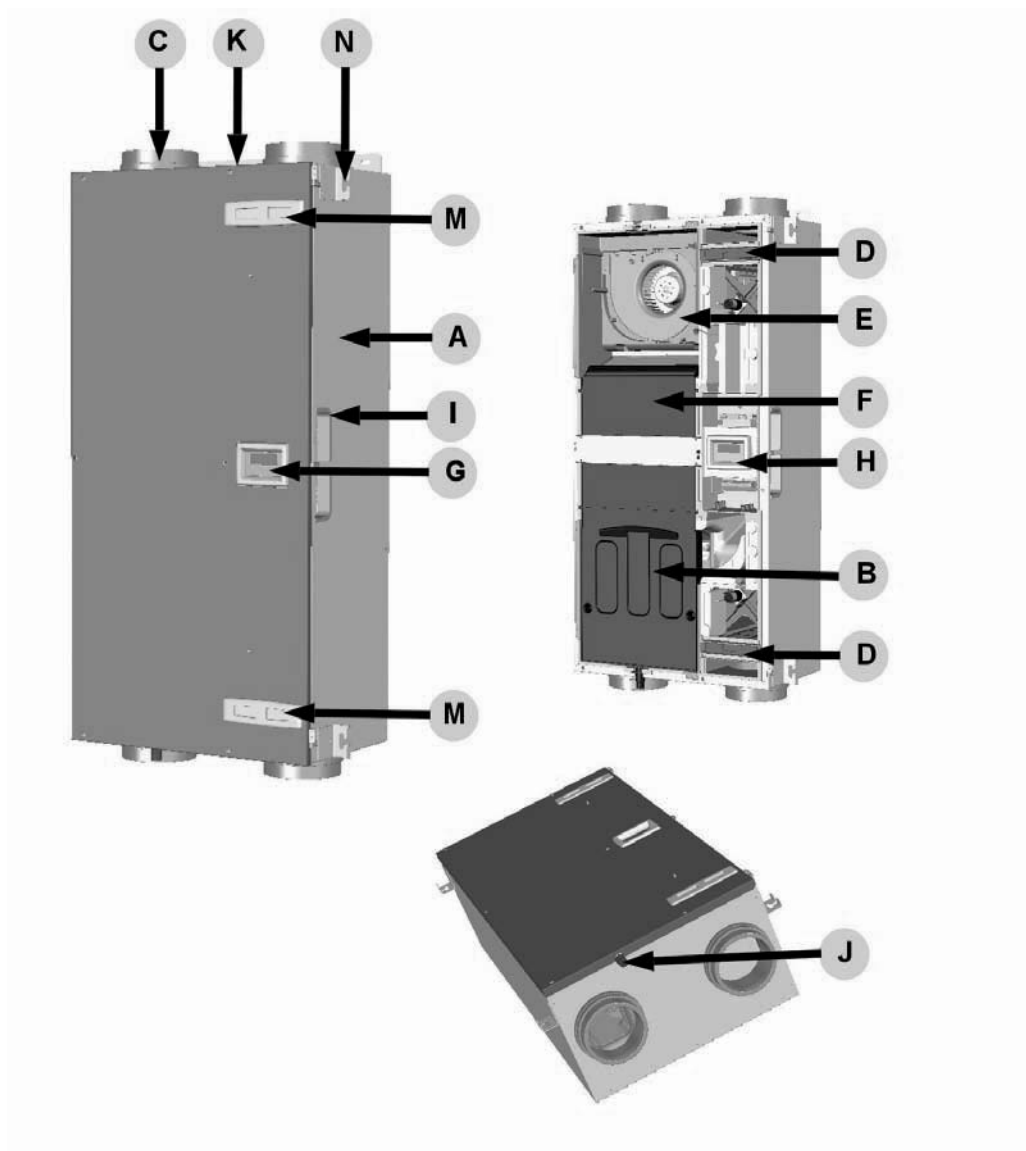

2.2 Technical specifications

ComfoAir 200 nL (normal air volumes)		
Position	Ventilation capacity	Power
Absent Setting	20 m ³ /h at 3 Pa	9 W
Low Setting	70 m ³ /h at 10 Pa	17 W
Medium Setting	120 m ³ /h at 30 Pa	30 W
High Setting	185 m ³ /h at 68 Pa	68 W
Maximum	255 m ³ /h at 125 Pa	143 W
Position	Ventilation capacity	Current
Absent Setting	20 m ³ /h at 3 Pa	0.08 A
Low Setting	70 m ³ /h at 10 Pa	0.14 A
Medium Setting	120 m ³ /h at 30 Pa	0.25 A
High Setting	185 m ³ /h at 68 Pa	0.55 A
Maximum	255 m ³ /h at 125 Pa	1.10 A

Electricity		
Power supply		230/50 V/Hz
Cos.phi		0.48 - 0.57

Supply fan noise level (at 0 m)		
Position	Ventilation capacity	Sound power
Absent Setting	20 m ³ /h at 3 Pa	37 dB(A)
Low Setting	70 m ³ /h at 10 Pa	49 dB(A)
Medium Setting	120 m ³ /h at 30 Pa	59 dB(A)
High Setting	185 m ³ /h at 68 Pa	66 dB(A)
Maximum	255 m ³ /h at 125 Pa	73 dB(A)

Exhaust fan noise level (at 0 m)		
Position	Ventilation capacity	Sound power
Absent Setting	20 m ³ /h at 3 Pa	36 dB(A)
Low Setting	70 m ³ /h at 10 Pa	39 dB(A)
Medium Setting	120 m ³ /h at 30 Pa	44 dB(A)
High Setting	185 m ³ /h at 68 Pa	52 dB(A)
Maximum	255 m ³ /h at 125 Pa	60 dB(A)

ComfoAir 200 HL (high air volumes)		
Position	Ventilation capacity	Power
Absent Setting	20 m ³ /h at 3 Pa	9 W
Low Setting	90 m ³ /h at 13 Pa	20 W
Medium Setting	185 m ³ /h at 68 Pa	68 W
High Setting	245 m ³ /h at 120 Pa	128 W
Maximum	255 m ³ /h at 125 Pa	143 W
Position	Ventilation capacity	Current
Absent Setting	20 m ³ /h at 3 Pa	0.08 A
Low Setting	90 m ³ /h at 13 Pa	0.16 A
Medium Setting	185 m ³ /h at 68 Pa	0.55 A
High Setting	245 m ³ /h at 120 Pa	0.99 A
Maximum	255 m ³ /h at 125 Pa	1.10 A

Electricity		
Power supply		230/50 V/Hz
Cos.phi		0.48 - 0.57

Supply fan noise level (at 0 m)		
Position	Ventilation capacity	Sound power
Absent Setting	20 m ³ /h at 3 Pa	37 dB(A)
Low Setting	90 m ³ /h at 13 Pa	53 dB(A)
Medium Setting	185 m ³ /h at 68 Pa	66 dB(A)
High Setting	245 m ³ /h at 120 Pa	72 dB(A)
Maximum	255 m ³ /h at 125 Pa	73 dB(A)

Exhaust fan noise level (at 0 m)		
Position	Ventilation capacity	Sound power
Absent Setting	20 m ³ /h at 3 Pa	36 dB(A)
Low Setting	90 m ³ /h at 13 Pa	42 dB(A)
Medium Setting	185 m ³ /h at 68 Pa	52 dB(A)
High Setting	245 m ³ /h at 120 Pa	56 dB(A)
Maximum	255 m ³ /h at 125 Pa	60 dB(A)

General Specifications		
HE Exchanger Material		Polystyrene
Interior Material		(E)PP / ABS
Thermal Yield		95%
Mass		30 kg

2.3 Dimension sketch

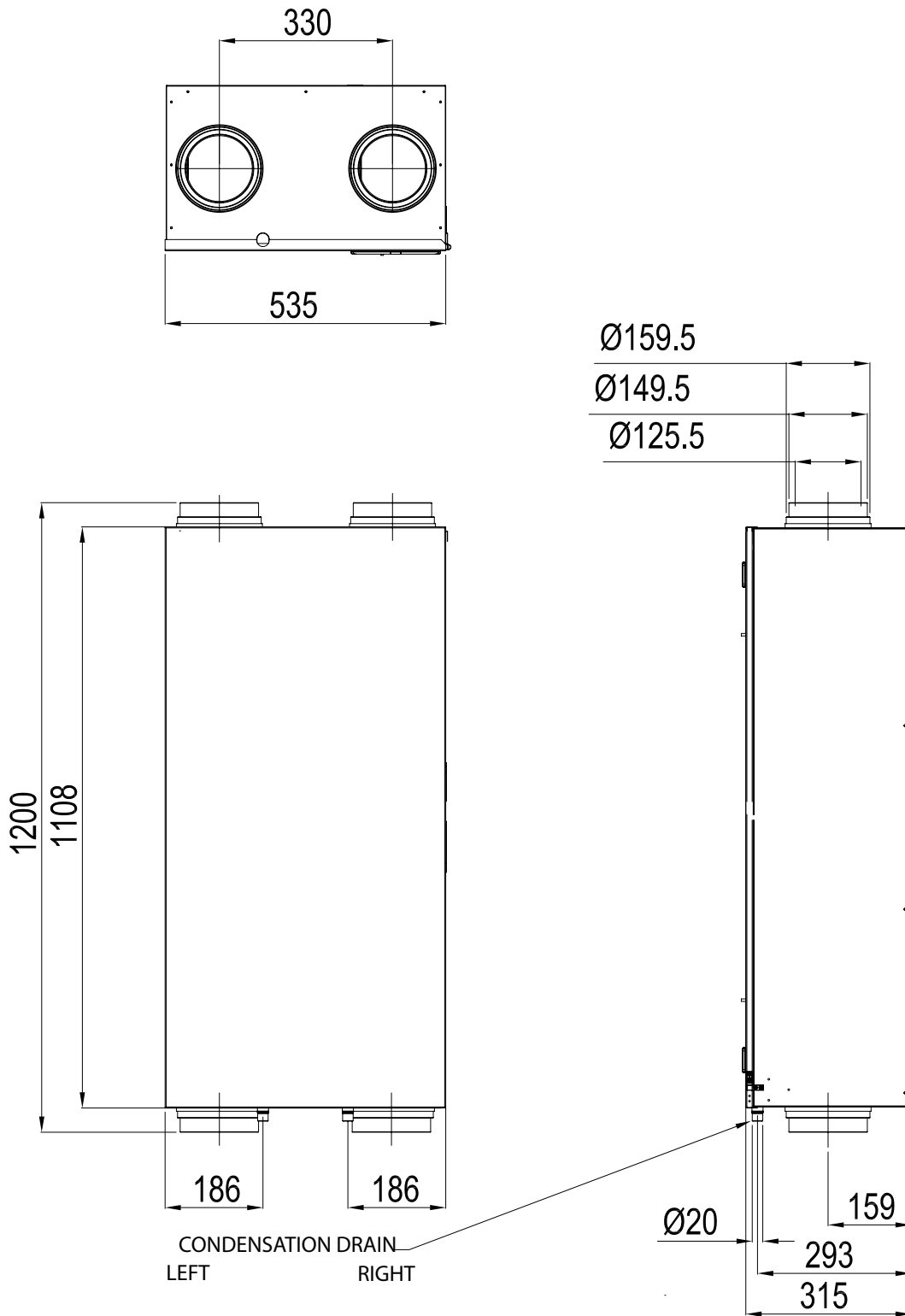

2.4 Installation conditions

In order to determine whether the ComfoAir can be installed in a certain area, the following aspects must be taken into account:

- The ComfoAir must be installed according to the general and locally applicable safety and installation regulations of power and water companies, as well as the instructions in this manual.
- The system must be fitted to allow sufficient room around the ComfoAir for the air connections and supply and exhaust ducts as well as for carrying out maintenance activities.
- The ComfoAir must be installed in a frost-free space. The condensation must be drained off frost-free, at a gradient and incorporate a 'U' bend.

 **We do not recommend installing the ComfoAir in areas with a higher average humidity (such as bathroom or toilet). This will prevent condensation on the outside of the ComfoAir.**

- The room must offer the following provisions:
 - Air duct connections.
 - 230V electrical connection.
 - Provisions for the condensation drain.
 - Wiring for a wired 3-position switch (optional).
- A gap should be left near the doors in order to ensure effective and draughtfree airflow in the house. A gap under the inside doors must be at least 10mm.

 **If these openings are obstructed, due to draught excluders or deep-pile carpet, the airflow in the house will stagnate. As a result, system performance will be compromised or fail altogether.**

2.5 Installation of the ComfoAir

2.5.1 Transport and unpacking

Take the necessary precautions when transporting and unpacking the ComfoAir.

 **Make sure the packing material is disposed of in an environmentally friendly manner.**

2.5.2 Checking the delivery

Contact your supplier immediately in case of damage or an incomplete delivery. The delivery should include:

- ComfoAir;
 - Check the identification plate to ensure that it is the required type.
- Ceiling mounting set;
- Wall mounting bracket;
- Documentation.

The ComfoAir is supplied in the following types:

Type
ComfoAir 200 L Basic
ComfoAir 200 R Basic
ComfoAir 200 L Luxe
ComfoAir 200 R Luxe
ComfoAir 200 L Luxe PH
ComfoAir 200 R Luxe PH

Meaning of the suffixes:

- L = Left version
- R = Right version
- PH = Contains a pre heater by default.
- Luxe = Contains a connection board with extra function by default.

ComfoSense panel (optional) can be ordered separately.

2.6 Mounting of the ComfoAir

The ComfoAir can be mounted two ways:

- On the ceiling;
- On the wall.

2.6.1 Mounting on the ceiling

Mount the ComfoAir to a ceiling with a minimum mass of at least 200 kg/m².

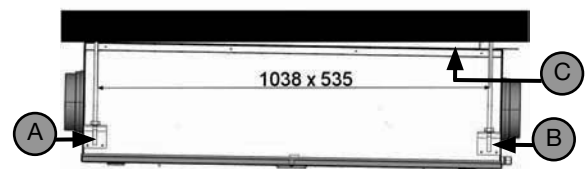

1. Fasten the four mounting brackets (A) (using the screws supplied) to the sides of the ComfoAir.
2. Fasten the two spacer brackets (C) (using the screws supplied) to the top of the ComfoAir on the side of the condensation drain (B). As long as the ceiling is level, this ensures a run-off of 2% to the condensation drain.
3. Mark the position of the mounting points on the ceiling.
4. Mount four pieces of studding (M8 or M10) extending 290 cm below the ceiling.
5. Screw suitable (securing) rings and nuts on the four rods.
6. Hang the unit on the rods and then screw the locknuts tight.
Allow a minimum 2% run-off to the condensation drain. If the ceiling is horizontal, the spacer brackets will automatically ensure that the ComfoAir hangs at the correct angle.
7. Mount the condensation drain to the ComfoAir with a coupling or removable pipe.
8. The air exhaust duct must be fitted with a double-walled or insulated roof passage. This prevents the formation of condensation between the roof boarding. In addition, the air exhaust duct must drain in the direction of the ComfoAir.
9. To prevent unnecessary temperature loss in either the summer or the winter, we recommend fitting thermal and damp-proof insulation to the supply ducts from the ComfoAir up to the supply valves.

Ensure that there is enough room under the ComfoAir for carrying out maintenance. The ComfoAir does not require any space at the sides for effective operation.

 **Do not mount the side of the ComfoAir against the wall due to the risk of impact sound.**

2.6.2 Mounting on the wall

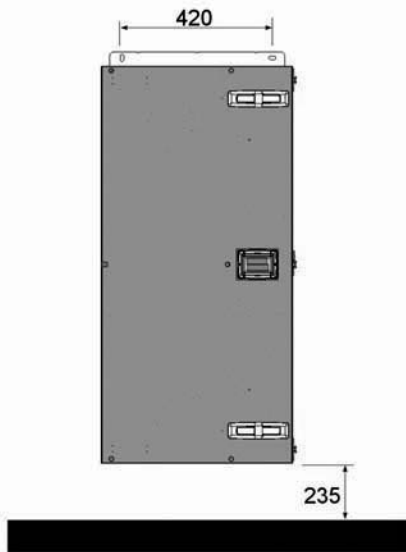

Mount the ComfoAir against a wall with a minimum mass of 200 kg/m².

1. Using a spirit level, fix the mounting bracket horizontally to the wall. Use M8 anchor bolts. Make sure there is enough space under the ComfoAir to mount the U bend.
2. Hang the unit on the mounting bracket.
3. Mount the condensation drain under the ComfoAir. The stated dimension of 235 mm is an indication only, and is dependent on the type of condensation drain selected.

Make sure to leave a minimum space of 1 metre in front of the ComfoAir for carrying out maintenance. The ComfoAir does not require any space at the sides for effective operation.

 **Do not mount the side of the ComfoAir against the wall due to the risk of impact sound.**

2.6.3 Connection of the air ducts

The following aspects must be taken into account, while installing the air ducts:

- Install the air exhaust duct so it drains in the direction of the ComfoAir;
- Insulate the outside air supply and the air exhaust duct between the roof/wall passage to render the ComfoAir damp proof. This prevents the formation of condensation on the outside of the ducts;
- To prevent unnecessary temperature loss in either the summer or the winter, we recommend fitting thermal and damp-proof insulation to the supply ducts from the ComfoAir up to the supply valves;
- Install the air ducts with a minimum \varnothing of 125 mm, as little air resistance as possible and free from air leakage;
- Install a silencer of at least 1m straight directly onto the supply and return air connections. For relevant advice, please contact Zehnder;

- When using flexible channels only Zehnder channel systems may be used. Any other flexible channel will disturb the basic operating principle of the balanced ventilation system;
- We recommend that the ventilation system is fitted with intake and exhaust valves made by Zehnder.

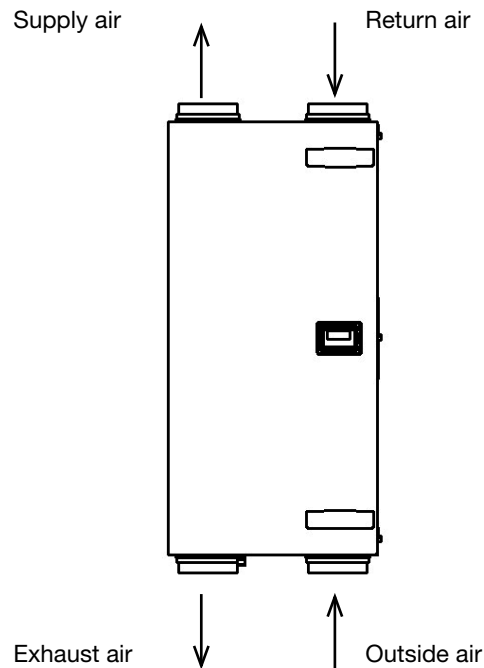

ComfoAir 200 - LEFT

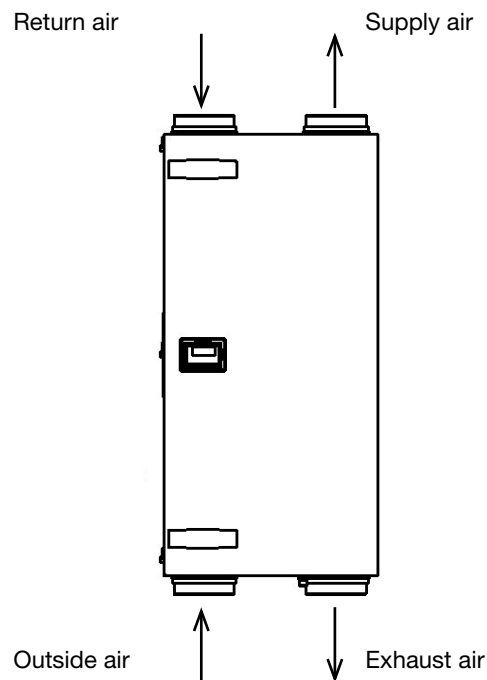

ComfoAir 200 - RIGHT

2.6.4 Connection of the condensation drain

Standard heat exchanger



ComfoAir 200 - LEFT



ComfoAir 200 - RIGHT

Warm exhaust air is cooled by the outside air in the heat exchanger. This causes the moisture in the indoor air to condense in the heat exchanger. The condensation water created in the heat exchanger is fed

to a PVC condensation drain.

The connection for the condensation drain has an external diameter of 20 mm and a ledge of 21.2 mm. It is located underneath the ComfoAir.

- Connect the condensation drain, via a pipe with coupling or hose, to the water seal (U bend) of the domestic waste-water system.

⚠ For future maintenance activities the condensation drain must be removable.

- Ensure the condensation drain pipe on ceiling-mounted units has a run-off to the U bend of at least 2%.
- Position the upper edge of the water seal at least 40 mm underneath the condensation drain of the ComfoAir.
- Make sure that the outer end of the pipe or tube exits is at least 60mm below the water level.

⚠ Ensure that the water seal connected to the domestic waste-water system is always full of water. This prevents the ComfoAir from sucking in any leakage air.

Enthalpy heat exchanger

When the ComfoAir is fitted with an enthalpy exchanger the moisture from the indoor air is transferred to the outside air. In this case there is no condensate which must be drained from the ComfoAir. Therefore a condensation drain is not necessary when an enthalpy exchanger is fitted.

⚠ Ensure that the condensation drain is sealed. This prevents the ComfoAir from sucking in any leakage air.

The condensation drain can be sealed with a standard screw-cap.

2.7 Commissioning the ComfoAir

After installation, the ComfoAir must be commissioned.

This can be done via the P menus on the digital operating device. These P menus can be used to enter various settings (ventilation programmes, in particular) for the ComfoAir. An overview of the available P menus is given below:

Menu	Options
P1	Reading statuses (from menu P2)
P2	Setting time delays
P3	Setting and reading the ventilation levels
P4	Setting and reading the temperatures
P5	Setting additional programmes
P6	Setting additional programmes
P7	Reading and resetting malfunctions (and system information)

Menu	Options
P8	Setting the RF input and analogue inputs (0-10V)
P9	Reading statuses (from menu P5 and P6)







P menus P1, P2 and P9 can be accessed by the user, mainly to read statuses and set time delays. The remaining P menus P3 to P8 are intended **solely** for the installer.

 **The ComfoAir's bypass valve will not work for the first 4 minutes after a power cut unless the programme mode is activated.**







2.7.1 Display on the unit

The ComfoAir can be operated and commissioned by means of a display. The display is a digital operating device which is mounted on the ComfoAir.



 MENU	select menu		up
 OK	OK		down
 supply off	supply off (led green)		supply on (led green)
	comfort temperature		

Shown in display

	Ventilation setting absent
	Ventilation setting low
	Ventilation setting medium
	Ventilation setting high
	Menu symbol
	Malfunction code (flashes)
	Bypass

Access to the menus

Se-quence	Press	Display	Description
1	MENU	P2	Time delay
2	▲ + ▼ (3 seconds)	P3	Press the buttons simultaneously.
3	▲	P4	Temperatures
4	▲	P5	Settings
5	▲	P6	Settings
6	▲	P7	Malfunction / Reset / Self-test
7	▲	P8	0 - 10V Inputs
8	▲	P9	Status

Example

Setting the MEDIUM POSITION of the supply fan to 40%.

Se-quence	Press	Display	Description
1	MENU	P2	Time delay
2	▲ + ▼ (3 seconds)	P3	Press the buttons simultaneously.
3	OK	P30	Exhaust fan Position A
4	▲ (6x)	P36	Select P36
5	OK	50	Current setting
6	▼ (10 x or press continuously)	40	Select 40
7	OK	P35	Value is 40
8	MENU	P3	
9	MENU	1	Fan setting

 **Some P menus (such as P1 and P9) can only be read.**

Leaving Reading menu

- At action point 6 press "MENU" (instead of "OK").

 **The display can not be used for setting the ventilation positions of the ComfoAir. The arrowkeys are only for setting the additional programmes.**

2.7.2 P menus for the installer

 **Menus with a line at minimum and maximum value are Reading menus.**

Menu P3 → Setting ventilation programmes







Submenu	Description	Ventilation programme values		
		Minimum	Maximum	General Reset
P30	Setting the capacity (in %) of the exhaust fan in ABSENT POSITION.	0% or 15%	97%	nL / HL 15% / 15%
P31	Setting the capacity (in %) of the exhaust fan in LOW POSITION.	16%	98%	nL / HL 35% / 40%
P32	Setting the capacity (in %) of the exhaust fan in MEDIUM POSITION.	17%	99%	nL / HL 50% / 70%
P33	Setting the capacity (in %) of the exhaust fan to HIGH POSITION.	18%	100%	nL / HL 70% / 90%
P34	Setting the capacity (in %) of the supply fan to ABSENT POSITION.	0% or 15%	97%	nL / HL 15% / 15%
P35	Setting the capacity (in %) of the supply fan in LOW POSITION.	16%	98%	nL / HL 35% / 40%
P36	Setting the capacity (in %) of the supply fan in MEDIUM POSITION.	17%	99%	nL / HL 50% / 70%
P37	Setting the capacity (in %) of the supply fan in HIGH POSITION.	18%	100%	nL / HL 70% / 90%
P38	Current capacity (in %) of the exhaust fan.	-	-	Current %
P39	Current capacity (in %) of the supply fan.	-	-	Current %

Menu P4 → Reading the temperatures

Submenu	Description	Temperature values		
		Minimum	Maximum	General Reset
P41	Comfort temperature	12 °C	28 °C	20 °C
P45	Current value of T1 (= outside air temperature)	-	-	Current °C
P46	Current value of T2 (= supply air temperature)	-	-	Current °C
P47	Current value of T3 (= return air temperature)	-	-	Current °C
P48	Current value of T4 (= exhaust air temperature)	-	-	Current °C

Menu P5 → Setting additional programmes





Submenu	Description	Additional programme values		
		Minimum	Maximum	General Reset
P50	Activation of the open fire programme.	0 (= No)	1 (= Yes)	0
P51	Confirming the presence of a pre heater	0 (= No)	1 (= Yes)	0
	 Only change if a pre heater is installed afterwards or a general reset is given.			

Submenu	Description	Additional programme values		
		Minimum	Maximum	General Reset
P52	Setting the pre heater programme. ■ 0; Guaranteed protection. ■ 1; High protection. ■ 2; Nominal protection. ■ 3; Economy.	0	3	2
	 In GUARANTEED PROTECTION MODE the pre heater is switched on soonest; this level offers the best guarantee of balanced ventilation. Vice versa, in ECONOMY MODE the pre heater switches on at the last possible moment; balanced ventilation is not guaranteed in this mode. When commissioning the ComfoAir, the pre heater programme can usually be left at level 2: NOMINAL MODE (factory setting). In areas with frequent cold spells in winter (frequent periods of -10°C or lower), level 1 should be selected: HIGH PROTECTION or even level 0: GUARANTEED PROTECTION.			
P54	Confirming the presence of a bypass.	0 (= No)	1 (= Yes)	1
	 The standard ComfoAir configuration includes a bypass. Therefore, leave the value at '1'.			
P56	Setting the required air volume in the house. ■ nL: "normal air volume". ■ HL: "high air volume".	nL	HL	HL
	 Setting the air volume is the starting point for programming the air specifications and setting the fans.			
P57	Setting the ComfoAir type. ■ Li = "Left-hand version". ■ Re = "Right-hand version".	Li	Re	Li
	 With delivery the ComfoAir is correctly pre-programmed at the factory.  After a general reset the pre-programming is lost and the setting must be reset. The correct setting is mentioned on the identification plate on top of the ComfoAir.			
P58	n/a	0	1	0
P59	Confirming the presence of an enthalpy exchanger. ■ 0; Enthalpy exchanger not fitted ■ 1; Enthalpy exchanger with RH sensor. ■ 2; Enthalpy exchanger without RH sensor.	0 (= No)	2 (= Yes)	0
	 Ensure the condensation drain is sealed.  If an enthalpy exchanger without a sensor is selected, then the safety programme will not be activated and malfunction alerts EA1 & EA2 will never occur.			

Menu P6 → Setting additional programmes

Submenu	Description	Additional programme values		
		Minimum	Maximum	General Reset
P60	Confirming the presence of a geothermal heat exchanger. ■ 0; Geothermal heat exchanger not fitted ■ 1; n/a ■ 3; Geothermal heat exchanger unregulated.	0 (= No)	3 (= Yes)	0
	 The ComfoAir 200 can only be fitted with an unregulated geothermal heat exchanger.			

Menu P7 → Reading malfunctions (and system information)

Submenu	Description	(Malfunction) information values		
		Minimum	Maximum	General Reset
P70	Current software version.	Version number of the software (without "v")		
P71	Most recent malfunction.	Code in accordance with alarm and malfunction alert		
P72	Malfunction before the most recent one	Code in accordance with alarm and malfunction alert		
P73	Malfunction before the most recent two	Code in accordance with alarm and malfunction alert		
P74	Resetting malfunction(s) ■ Set value to '1' and press "OK" on the display. ■ Set value to '1' and press "OK" on the ComfoSense panel.	0	1 (= activate)	0
P75	General reset. ■ Press "OK" on the display for at least 5 seconds to carry out a general reset. ■ Set value to '1' and press "OK" on the ComfoSense panel to carry out a general reset. All original software settings are restored following a general reset.	0	1 (= activate)	0
	 After a general reset, the ComfoAir will ask you to reset the "nL / HL" (see P56) and "Li / Re" (see P57) settings.  Following a general reset, all settings and programmes need to be checked and set to the right value.			
P76	Self-testing the ComfoAir	0	1 (= activate)	0
	 <ul style="list-style-type: none"> • The ComfoAir will run at maximum Rotations Per Minute (RPM). • The bypass valve will open and close. • The pre heater valve will open and close after the bypass has closed (If a pre heater is fitted). 			
P77	Resetting filter dirty counter	0	1 (= activate)	0
	 <p>This resets the counter that triggers a dirty filter alert on the ComfoAir. This allows the filter to be cleaned or replaced before the dirty filter alert appears.</p>			

Menu P8 → Setting the RF input and digital inputs (0-10V)

Submenu	Description	Analogue input values		
		Minimum	Maximum	General Reset
810	Analogue input 1 0= not fitted 1= fitted	0	1	0
811	0= controlling 1= programming (analogue input 1)	0	1	0
812	set point analogue input 1 (programming)	0	100	50
813	min. setting analogue input 1	0	99	0
814	max. setting analogue input 1	0	100	100
815	0=positive analogue input 1 1=negative setting analogue input 1	0	1	0
816	read-out analogue input 1	0	100	-
850	RF input 1 0= not fitted 1= fitted	0	1	0
851	0= controlling 1= programming (RF input 1)	0	1	0
852	set point RF input 1 (programming)	0	100	50
853	min. setting RF input 1	0	99	0
854	max. setting RF input 1	0	100	100
855	0=positive RF input 1 1=negative setting RF input 1	0	1	0
856	Read-out RF input	0	100	-

2.8 Programming air specifications

After installation, the ComfoAir must be programmed.

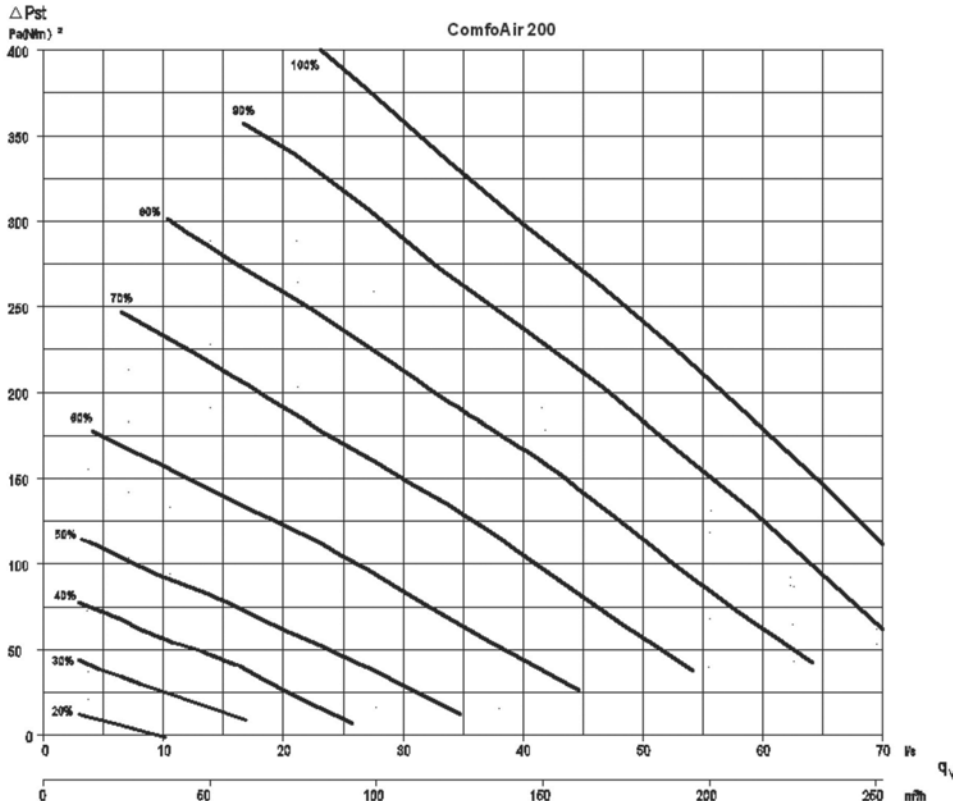

This can be done using the air specifications of the ComfoAir above.

The default settings of the ComfoAir nL are:

Position ABSENT	15%
Position LOW	35%
Position MEDIUM	50%
Position HIGH	70%

The default settings of the ComfoAir HL are:

Position ABSENT	15%
Position LOW	40%
Position MEDIUM	70%
Position HIGH	90%

Follow this procedure to programme the ComfoAir (after installation):

- Set the ComfoAir in programming mode.
 - ComfoSense Panel:
 - Press OK. The display shows SHIFT for 8 seconds.
 - Press MENU before the SHIFT text disappears. The display now shows COMF.
 - Press \triangle or ∇ to select INIT.
 - Press OK. The display flashes the text INIT ON.
 - Confirm with OK. The display shows OK for 2 seconds.

The text INIT is visible in the main menu.
 - Display: Press simultaneously for at least 3 seconds on " \square " and " \square " until "InR" appears on the display.

In programming mode, the bypass and Pre heater valves are always closed. After 30 minutes, the ComfoAir automatically terminates the programming mode.



- Close all windows and outside doors.
- Close all inside doors.
- Check the presence of structural overflow provisions.
- Check if both fans function in the three speed settings.
- Switch the ComfoAir to high speed.
- Install all valves and set the valves according to the settings given or as set in the reference house.
- Change the fan settings in P menus P30 to P37 of the digital operating device if required.

Use the chart of the ComfoAir's air specifications to set the fans.

- In the event that the currently set air volumes still deviate too much: Adjust the valves.
- Check the entire installation again, after all valves have been set.
- Switch the ComfoAir (back) to ventilation position 1.
 - ComfoSense Panel:
 - Press OK. The display shows SHIFT for 8 seconds.
 - Press MENU before the SHIFT text disappears. The display now shows COMF.
 - Press \triangle or ∇ to select INIT.
 - Press OK. The display flashes the text INIT

ON.

e. Confirm with OK. The display shows OK for 2 seconds.

- Display: Press simultaneously for at least 3 seconds on "  " and "  " until "InR" disappears on the display.

2.9 Maintenance by the installer

The following maintenance must be carried out by the installer:

- Inspecting and (if necessary) cleaning the heat exchanger;
 - Inspecting and (if necessary) cleaning the fans.
- A concise explanation of these maintenance activities is given in the paragraphs below.

 **Check the condensation drain once every 5 years.**

 **Failure to carry out (periodic) maintenance on the ComfoAir ultimately compromises the performance of the ventilation system.**

2.9.1 Inspecting and cleaning the heat exchanger

 **Check the heat exchanger once every 2 years**

1. Disconnect the power from the ComfoAir.
2. Remove the filter caps from the ComfoAir.
3. Release the front panel by unscrewing the screws (C).

 **The front swings forward on ceiling-mounted units.**

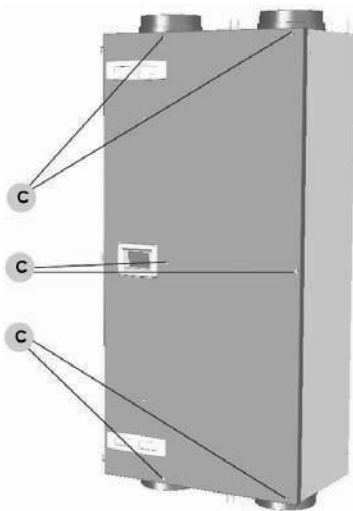

4. Lift front panel from its hinges.
5. Disconnect condensation drain.

 **Take care not to trap your fingers when mounting front panel.**

6. Remove the leakage tray by removing the screws (D and E).

 **The heat exchanger and leakage tray may contain water!**

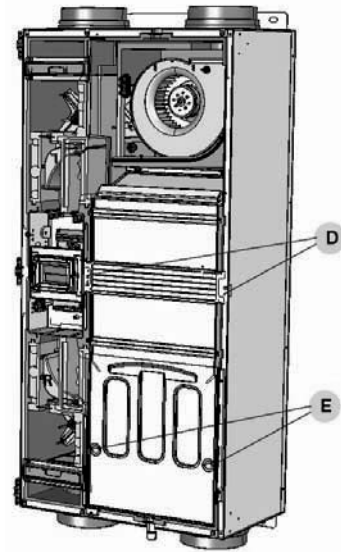

7. Rotate locking nuts (G) on heat exchanger a quarter of a turn.

 **The heat exchanger may fall downwards on ceiling-mounted units, so ensure the heat exchanger is supported when rotating the locking nuts.**

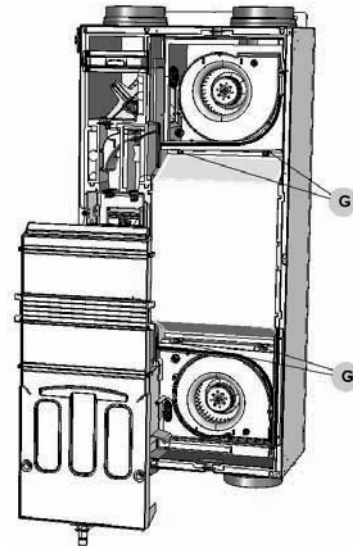

8. Pull strip to remove heat exchanger (D).
9. Inspect and if necessary clean the heat exchanger.
 - Use a soft brush to clean the fins.
 - Use a vacuum cleaner or air gun (no high pressure) to remove dirt and dust.

 **Always clean against the direction of the air-flow. This prevent dirt from getting stuck in the heat exchanger.**

Only Standard heat exchanger:

- a. Submerge the heat exchanger several times in

- hot water (max. 40 °C).
- Rinse the heat exchanger with clean hot tap water (max. 40 °C).
 - Clasp the heat exchanger between both hands (on the coloured side surfaces) and shake the water from the heat exchanger.

⚠ Only an enthalpy exchanger with a blue cover can be washed with water. When having an enthalpy exchanger with a white cover never wash it with water.

⚠ Do not use aggressive cleaning agents or solvents.

👉 If the fans or preheater element filter also need maintenance do not re-install the heat exchanger yet.

- If no more maintenance is necessary install all parts in reverse order, reconnect the power and carry out the self-test in accordance with menu P76.

⚠ Fasten the screws to a maximum of 1.5 Nm. This is roughly equal to setting 2 of an average battery-powered drill.

2.9.2 Inspecting and cleaning the fans

👉 Check the fans once every 2 years.

- Remove the heat exchanger as instructed in the maintenance chapter of the heat exchanger
- Remove** the inflow nozzle (F) by unscrewing the 2 screws surrounding the scroll casing.
- Inspecting and if necessary clean the fans (O).
 - Use a soft brush to clean the fan impellers.
 - Use a vacuum cleaner to remove dust.

⚠ Do not damage the fan impellers or temperature sensor.

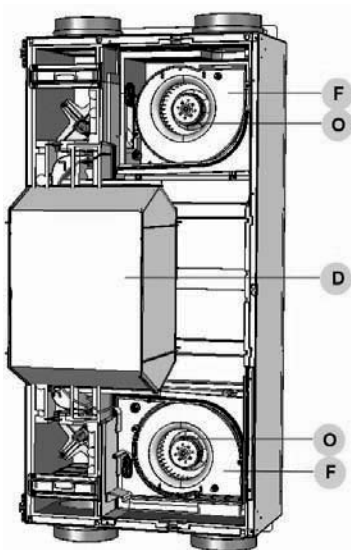

- Install all parts in reverse order.
- Carry out the self-test in accordance with menu P76.

⚠ Fasten the screws to a maximum of 1.5 Nm. This is roughly equal to setting 2 of an average battery-powered drill.

2.10 Malfunctions

Malfunctions in the ComfoAir are reported as follows:

- The malfunction alert appears on the ComfoSense panel;
- The malfunction alert appears on the display;
- The malfunction indicator on the 3-position switch lights up.

Malfunction alerts may not appear on the digital operating device in all cases, even though there is a malfunction (or problem). A concise explanation of both types of malfunction (or problem) is given in the following paragraphs.

2.10.1 Malfunction alerts on the digital operating device

In the event of a malfunction, the corresponding malfunction code will be displayed on the digital operating device of the ComfoAir.

Below is a list of the malfunction alerts on the digital operating device.

In the chapter about troubleshooting is explained how to solve these malfunctions

Code	Description
A0	NTC sensor TGe is defective. (= geothermal heat exchanger temperature)
A1	NTC sensor T1 is defective. (= outside air temperature)
A2	NTC sensor T2 is defective. (= supply air temperature)
A3	NTC sensor T3 is defective. (=return air temperature)
A4	NTC sensor T4 is defective. (= exhaust air temperature)
A5	Malfunction in the bypass motor.
A6	Malfunction in the Pre heater motor.
A7	Pre heater does not heat sufficiently.
A8	Pre heater becomes too hot
E1	Exhaust fan not rotating.
E2	Supply fan not rotating.
EA1	Enthalpy sensor measures excessive Relative Humidity (RH) values.
EA2	No communication between the enthalpy sensor and the ComfoAir.
COMM ERROR	No communication between the ComfoSense panel and the ComfoAir.
FLTR	Internal Filter is dirty.
FLTR EXT	External Filter is dirty.

2.10.2 3-position switch with malfunction indicator

The 3-position switches that are fitted with a malfunction indicator show when a malfunction or filter dirty alert has occurred. Depending on the type of the 3-position switch, this is done in one of the following two ways:

- 3-position switch with malfunction indicator.
In the event of a malfunction or filter dirty alert the indicator lights up;
- Wireless 3-position switch with malfunction indicator.

The malfunction indicators will light up once this 3-position switch is used. One indicator will light up green to indicate communication has been established. Subsequently, in the event of a malfunction or filter dirty alert both indicators will flash red 3 times. After that, both indicators will light up green once more.



2.10.3 What to do in the event of a malfunction / Troubleshooting

Below are a number of troubleshooting tips for the malfunction alerts described previously which can appear on the digital operating device in the event of a malfunction.

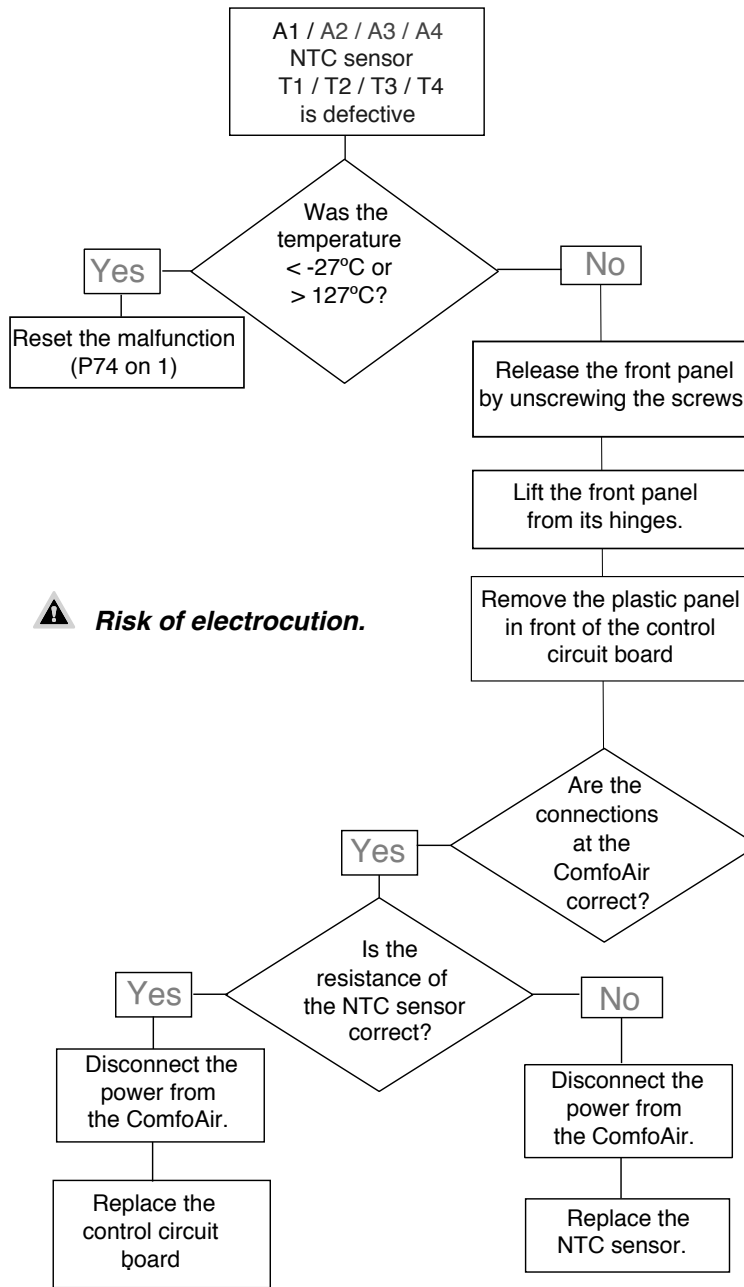

⚠ Risk of electrocution.

Resistance table for (NTC) temperature sensors:

Temperature [°C]	Resistance [KΩ]		
	MIN.	MID.	MAX.
10	19,570	19,904	20,242
15	15,485	15,712	15,941
18	13,502	13,681	13,861
19	12,906	13,071	13,237
20	12,339	12,491	12,644
21	11,801	11,941	12,082
22	11,291	11,420	11,550
25	9,900	10,000	10,100
30	7,959	8,057	8,155

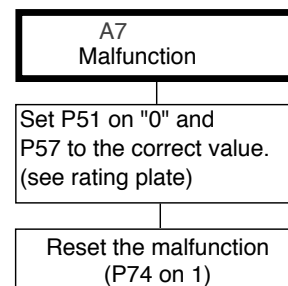
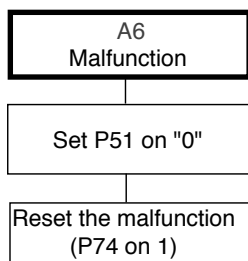

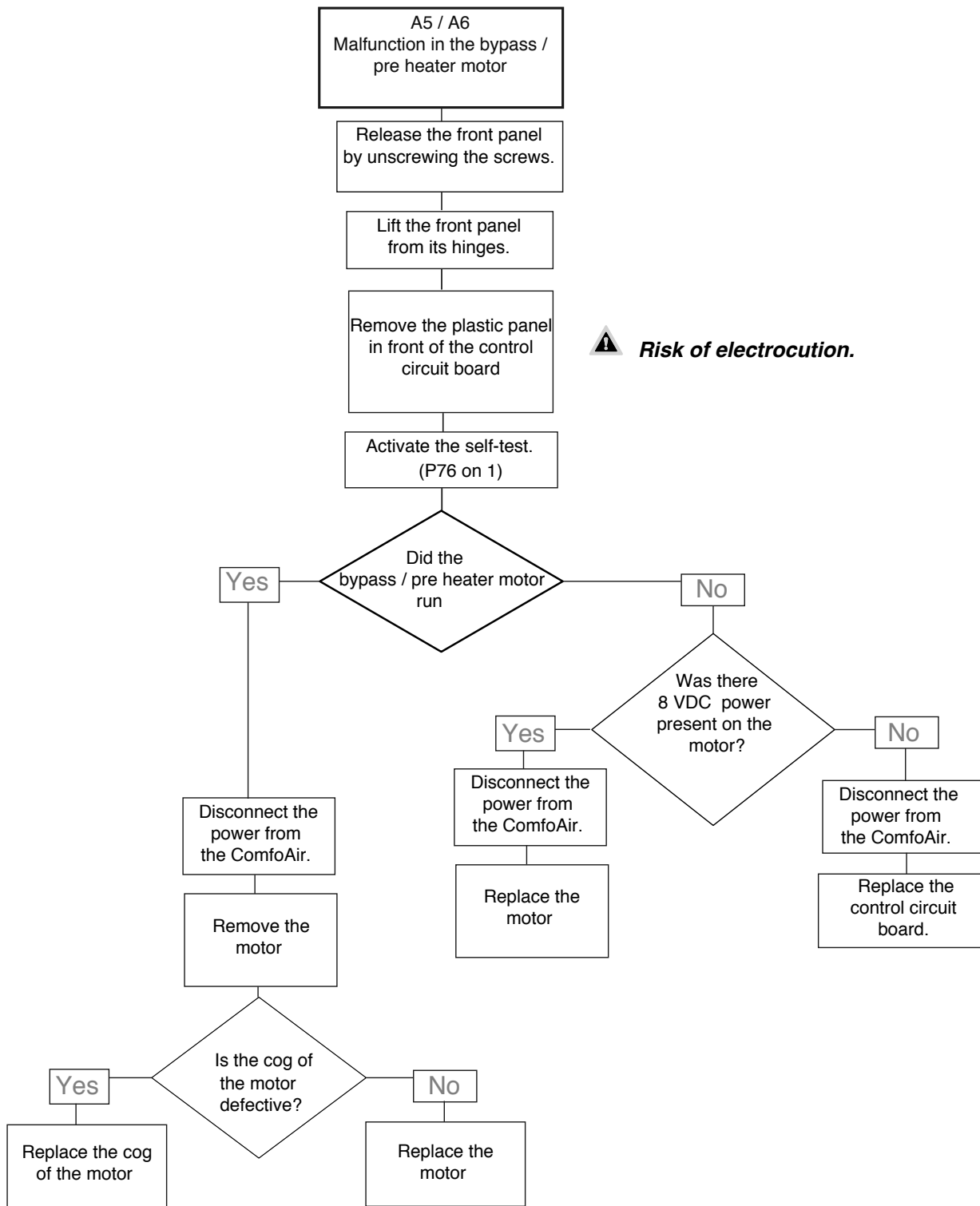

☞ This error will appear when after 3 minutes of switching on the pre heater the temperature increase of T1 is less than 4°C. This can also happen when there is too much cold air passing through the pre heater. In that case reduce the airflow and reset the malfunction (P74 on 1).

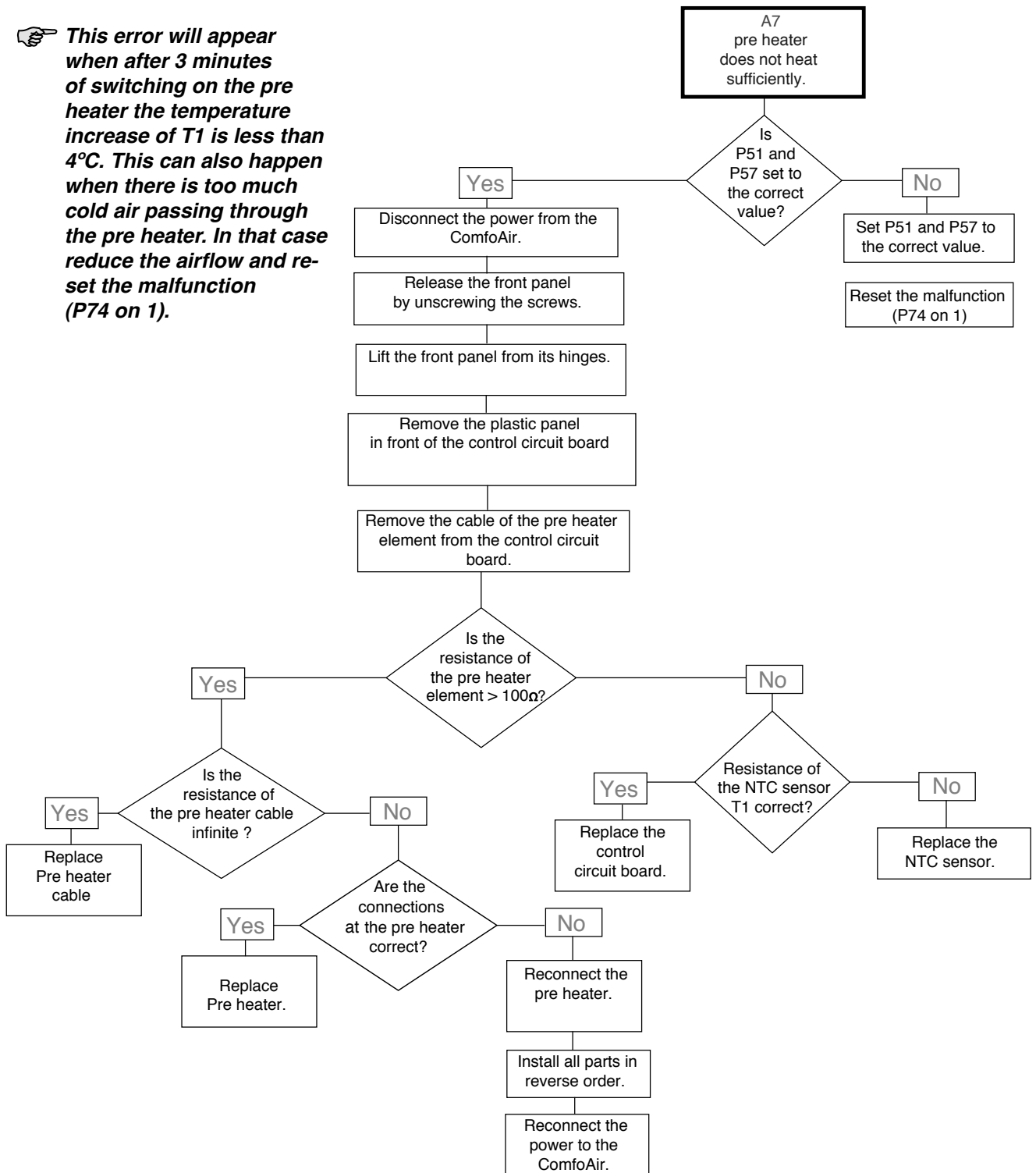

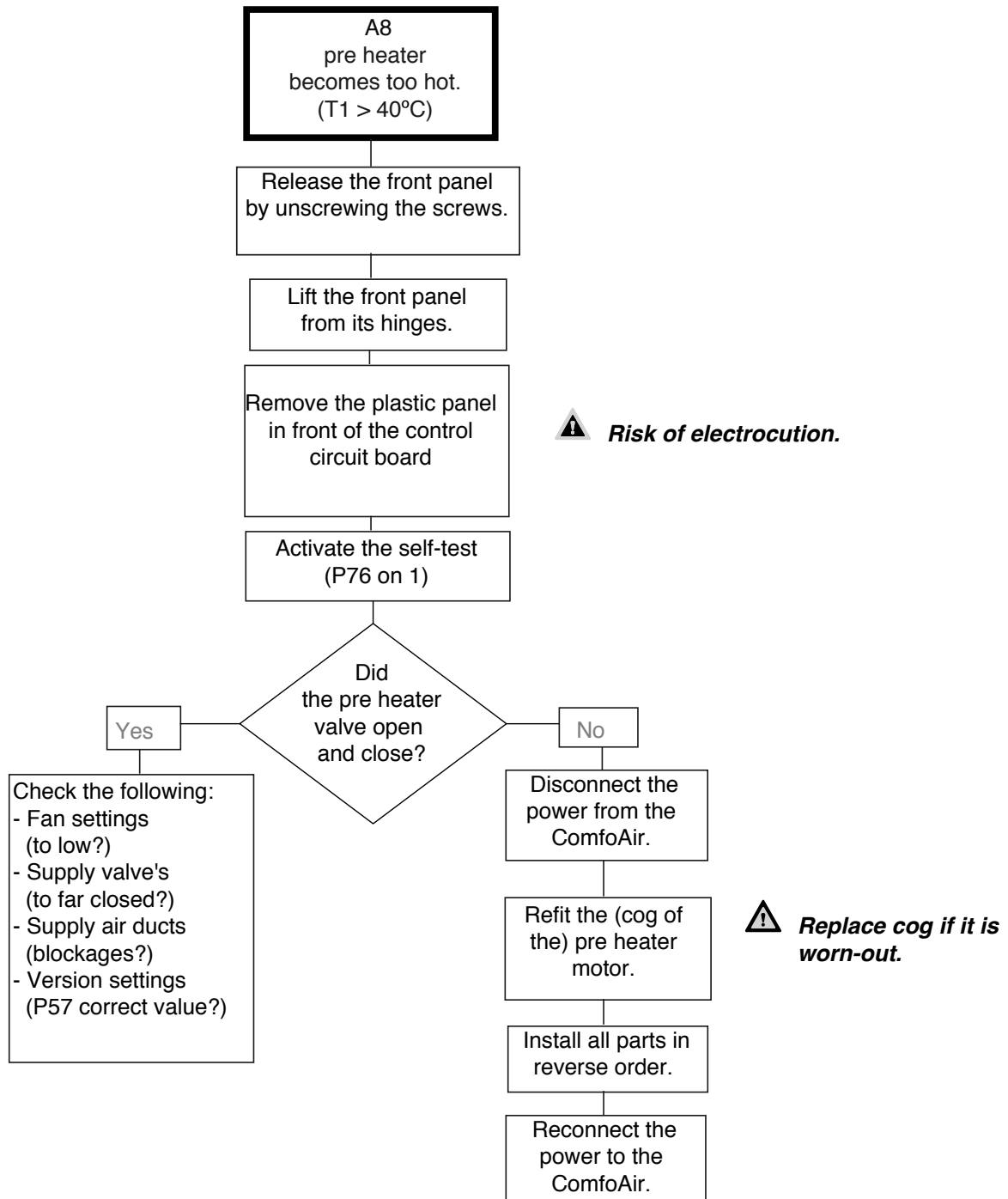

⚠ Risk of electrocution.

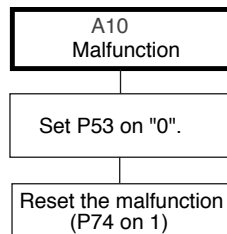
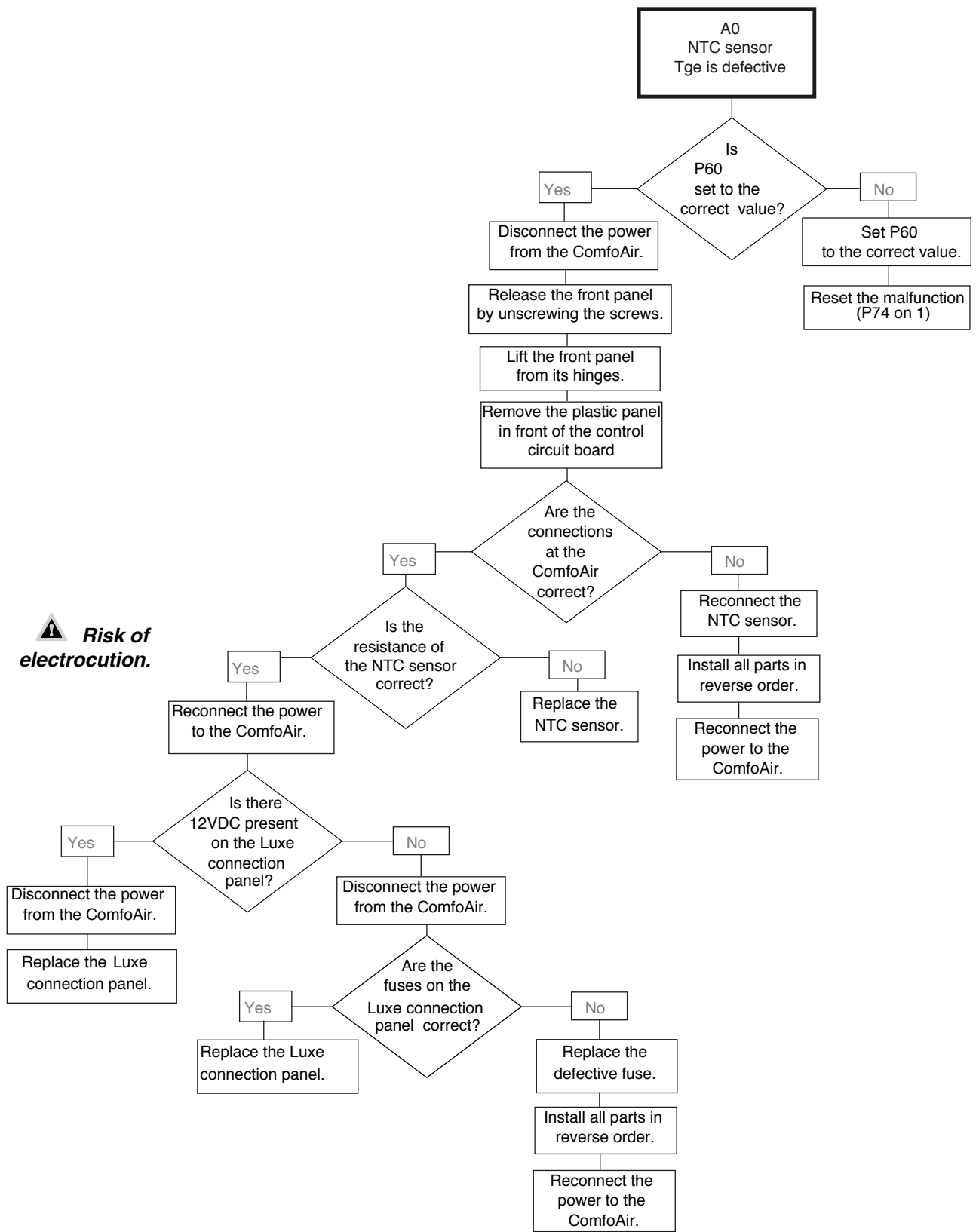

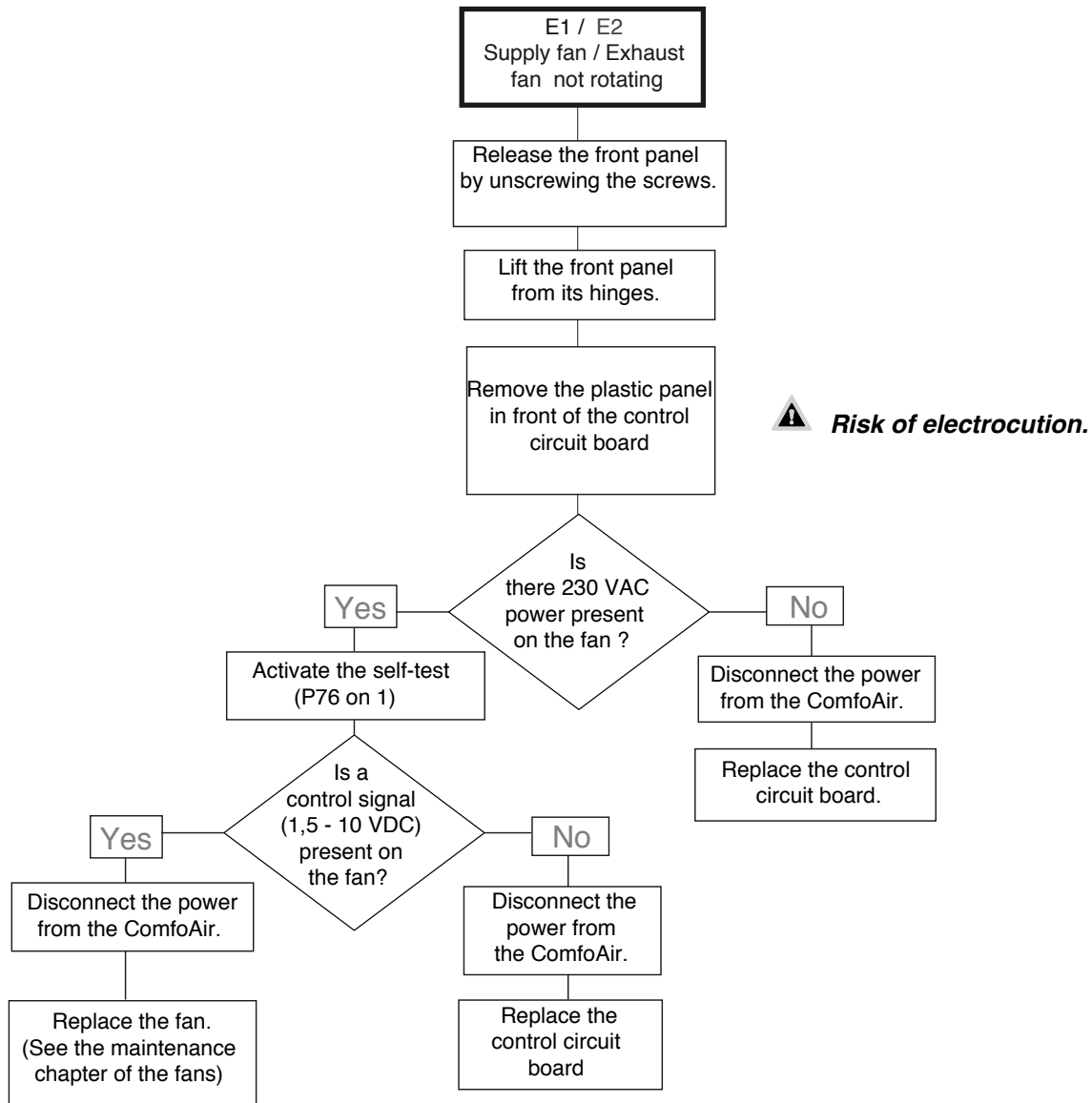

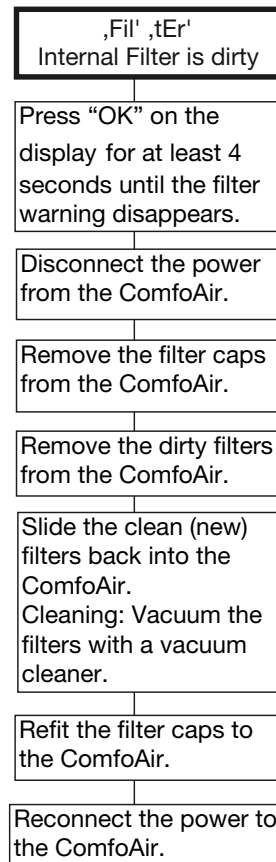
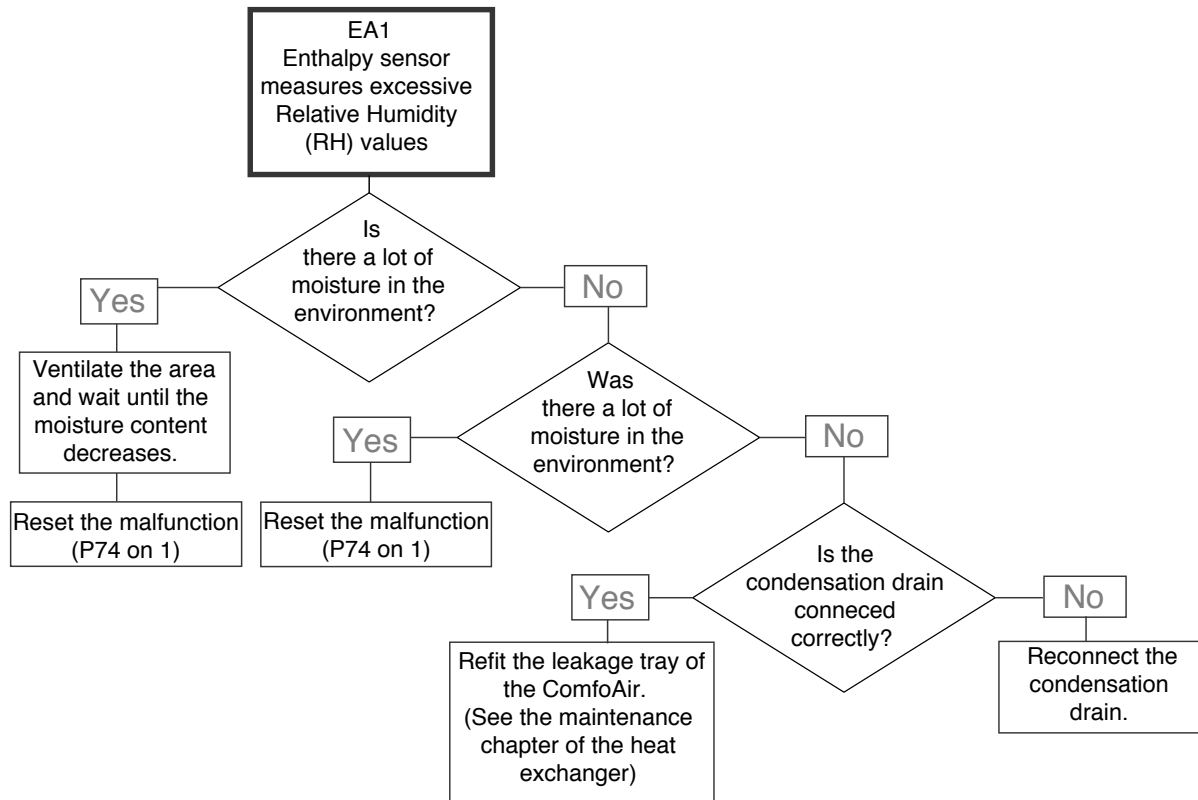

⚠ Risk of electrocution.

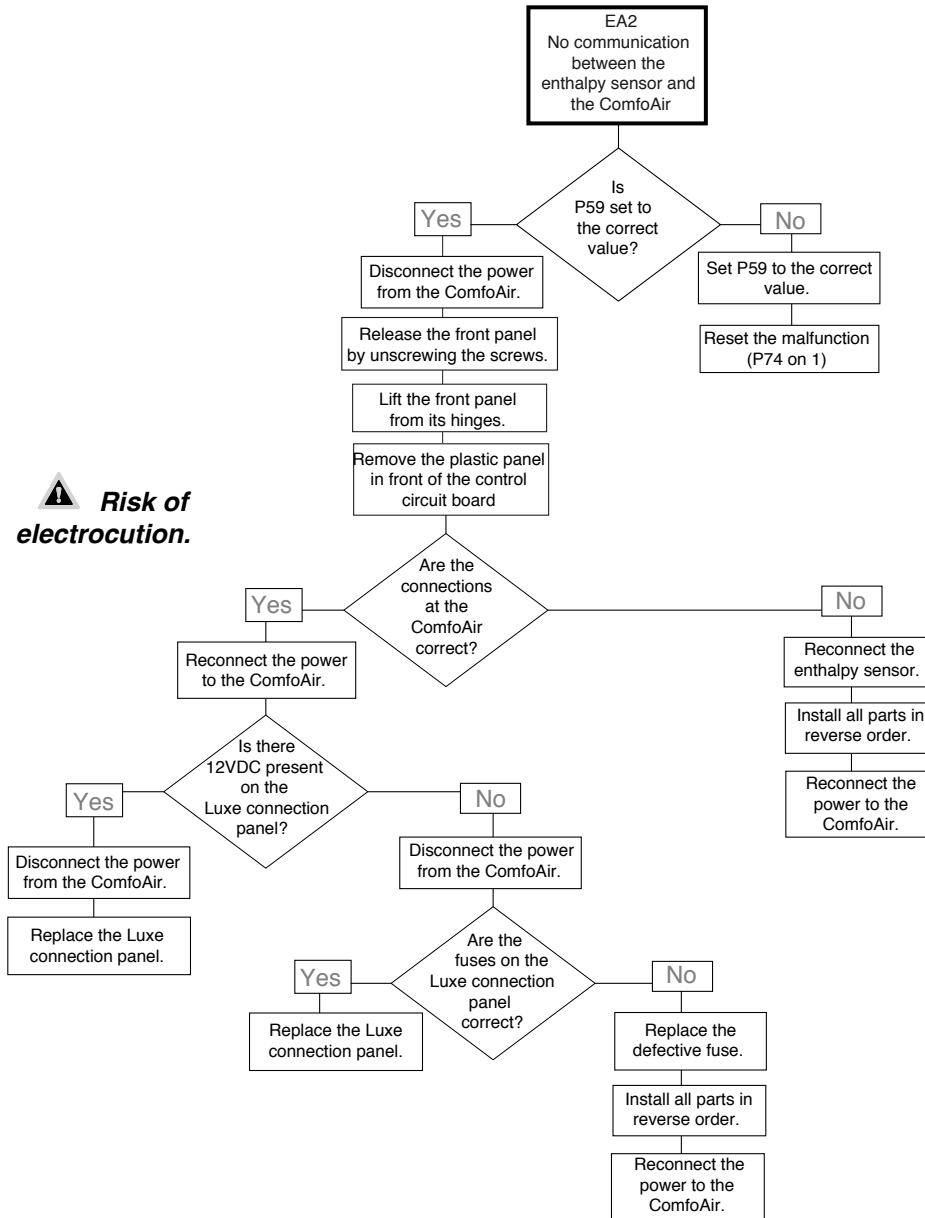

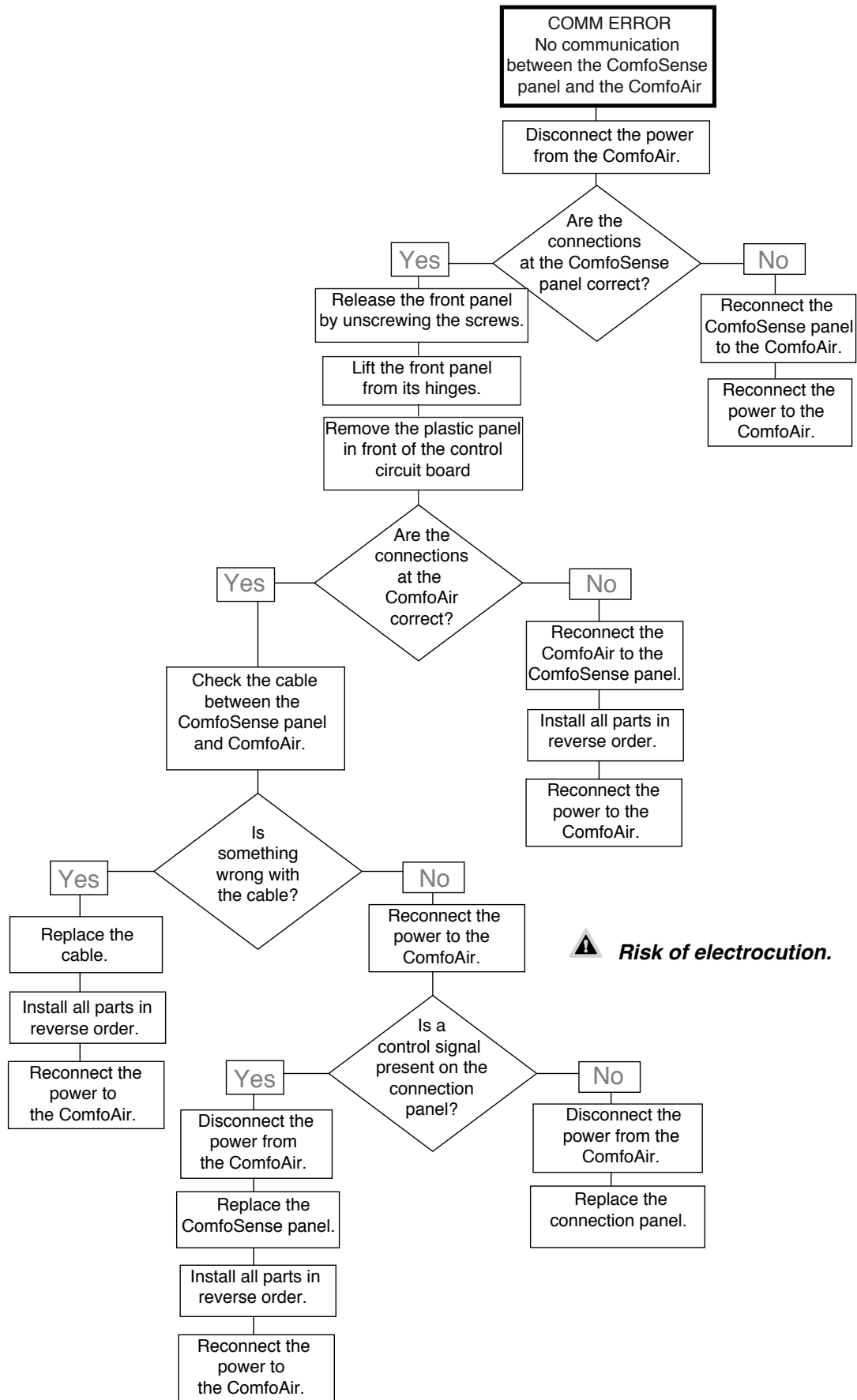

FLTR
Internal Filter is dirty

Press OK on the ComfoSense panel 2x to reset the FLTR warning.

Disconnect the power from the ComfoAir.

Remove the filter caps from the ComfoAir.

Remove the dirty filters from the ComfoAir.

Slide the clean (new) filters back into the ComfoAir.
Cleaning: Vacuum the filters with a vacuum cleaner.

Refit the filter caps to the ComfoAir.

Reconnect the power to the ComfoAir.

FLTR EXT
External Filter is dirty

Clean or replace the External filter according to its own instruction.

2.10.4 Malfunctions (or problems) without alerts

An overview of the malfunctions (or problems) without notifications is given below.

Problem/Malfunction	Indication	Check / action
System switched off	Power supply on	Check the fuse on the control circuit board ■ If the fuse is defective, replace fuse ■ If the fuse is OK, the control circuit board is defective and must be replaced
	No power supply	Mains power is off
High intake temperature in summer	Bypass remains closed	Reduce the comfort temperature
	ComfoAir is still in Winter mode: Bypass remains closed	Checking the Mode of the ComfoAir is possible with special read-out software ■ Wait until ComfoAir switches to Summer mode
Low intake temperature in winter	Bypass stays open	Increase the comfort temperature
Little or no air supply; shower remains damp	Filters blocked	Replace the filters
	Valves blocked	Clean the valves
	Exchanger clogged by dirt	Clean the exchanger
	Exchanger frozen	Defrost the exchanger
	Fan dirty	Clean the fan
	Ventilation ducts blocked	Clean the ventilation ducts.
	ComfoAir is in frost-protection operation	Wait until the weather warms up.
Too noisy	Fan bearings defective	Replace the fan (bearings).
	Fan settings to high	Change the fan (settings)
	Slurping noise ■ U bend. is empty ■ U bend. does not seal properly	Reconnect the U bend
	Whistling noise ■ An air gap somewhere	Seal the air gap
	Airflow noise ■ Valves do not close onto duct ■ Valves not open far enough	Reinstall the valves Reset the valves
	Condensation leak	Unblock the condensation drain.
Corded 3-position switch not working	Condensation drain clogged	Check whether the connections are correct
	Cabling is not correct Switch is defective	Check the wiring circuit of the 3-position switch by measuring the voltage: ■ Voltage only on N & L3: [Fans rotate in position 1] ■ Voltage only on N & L3 & L2: [Fans rotate in position 2] ■ Voltage only on N & L3 & L1 or N & L3 & L2 & L1: [Fans rotate in position 3]
Wireless 3-position switch not working	Battery is discharged	Check the battery. ■ Replace the battery (if necessary).
	Switch is not correctly tuned.	Remove the power briefly from the ComfoAir. Shortly after reconnecting the power tune the switch again

2.11 Service parts

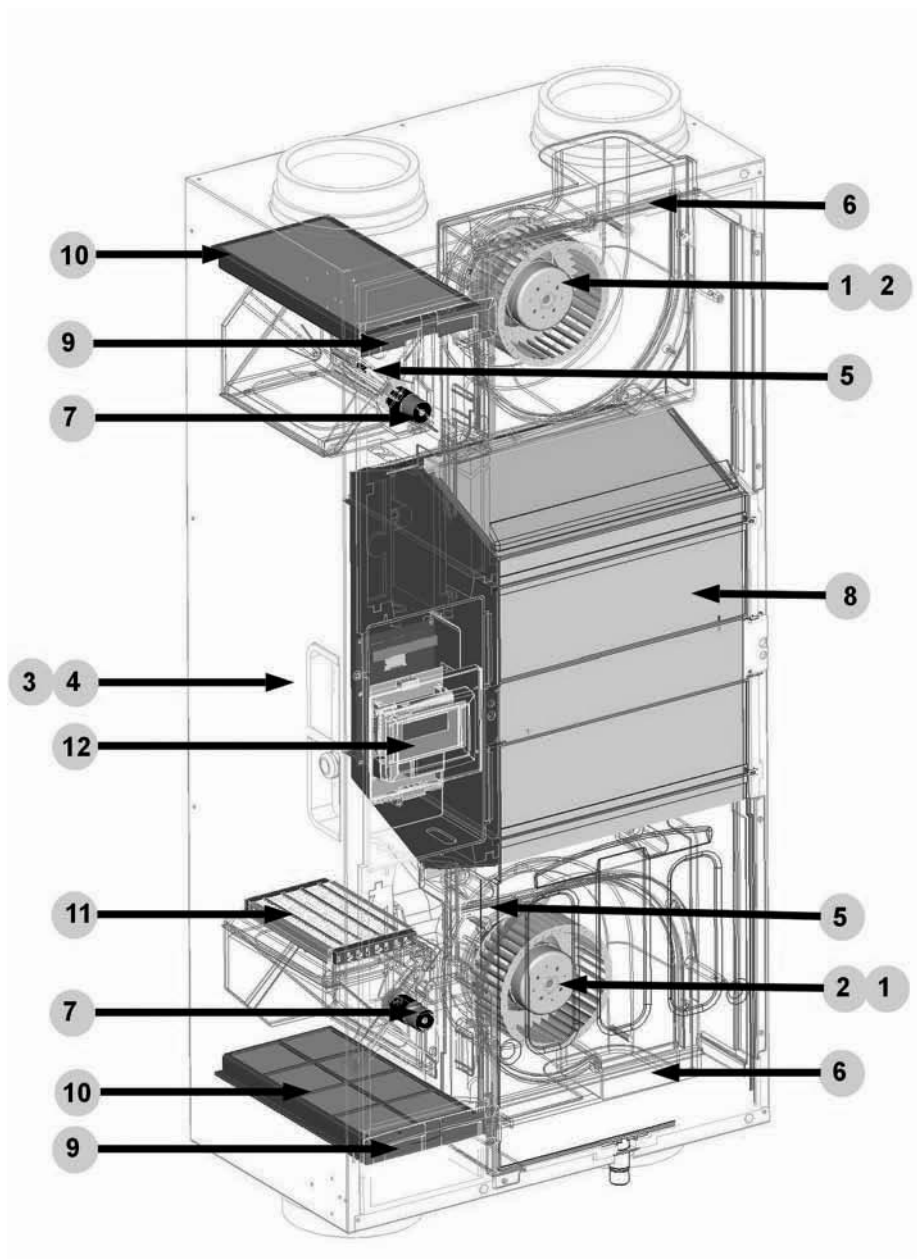

The following table contains an overview of the spare parts available for the ComfoAir.

Number	Part	Article number
1	Fan Right-hand (Green)	400200018
2	Fan Left-hand (Red)	400200019
3	Control panel	400300051
4	Connector panel	400300031
5	Temperature sensor T1 / T3	400300049
6	Temperature sensor T2 / T4	400300048
7	Servo motor & cable (for the bypass and the Pre-heater)	400300050
8	Heat exchanger	400400012
9	Filter cap	400100021
10	Filter	400100014
11	Pre-heater	400300060
12	Display	400300034

2.12 Wiring diagram: ComfoAir 200 Basic – LEFT-HAND version

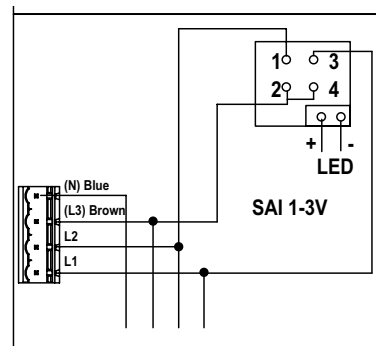
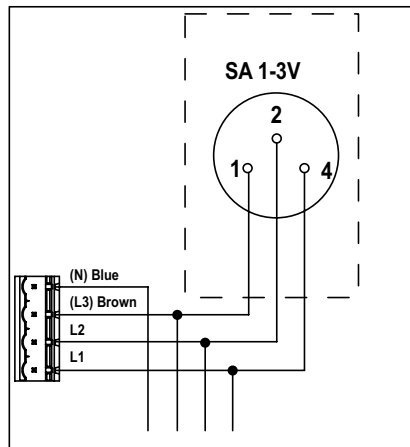
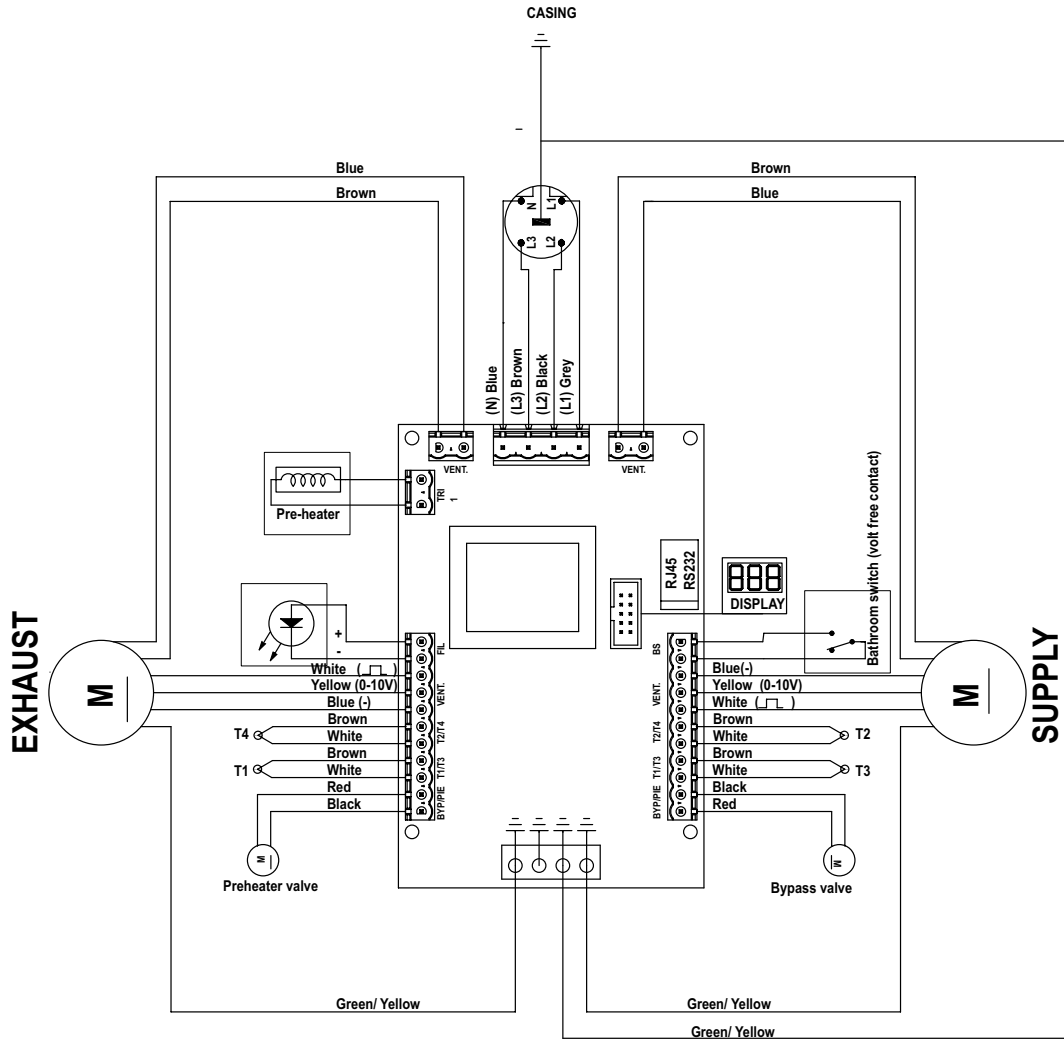

2.13 Wiring diagram: ComfoAir 200 Basic – RIGHT-HAND version

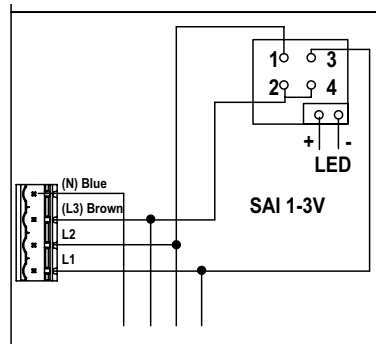
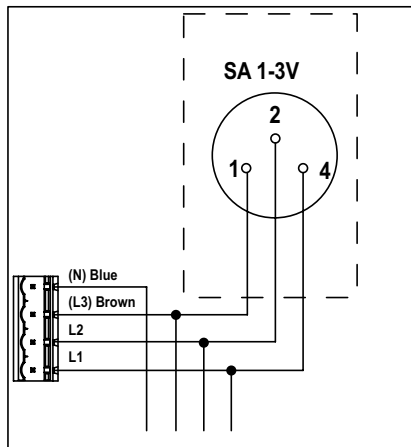
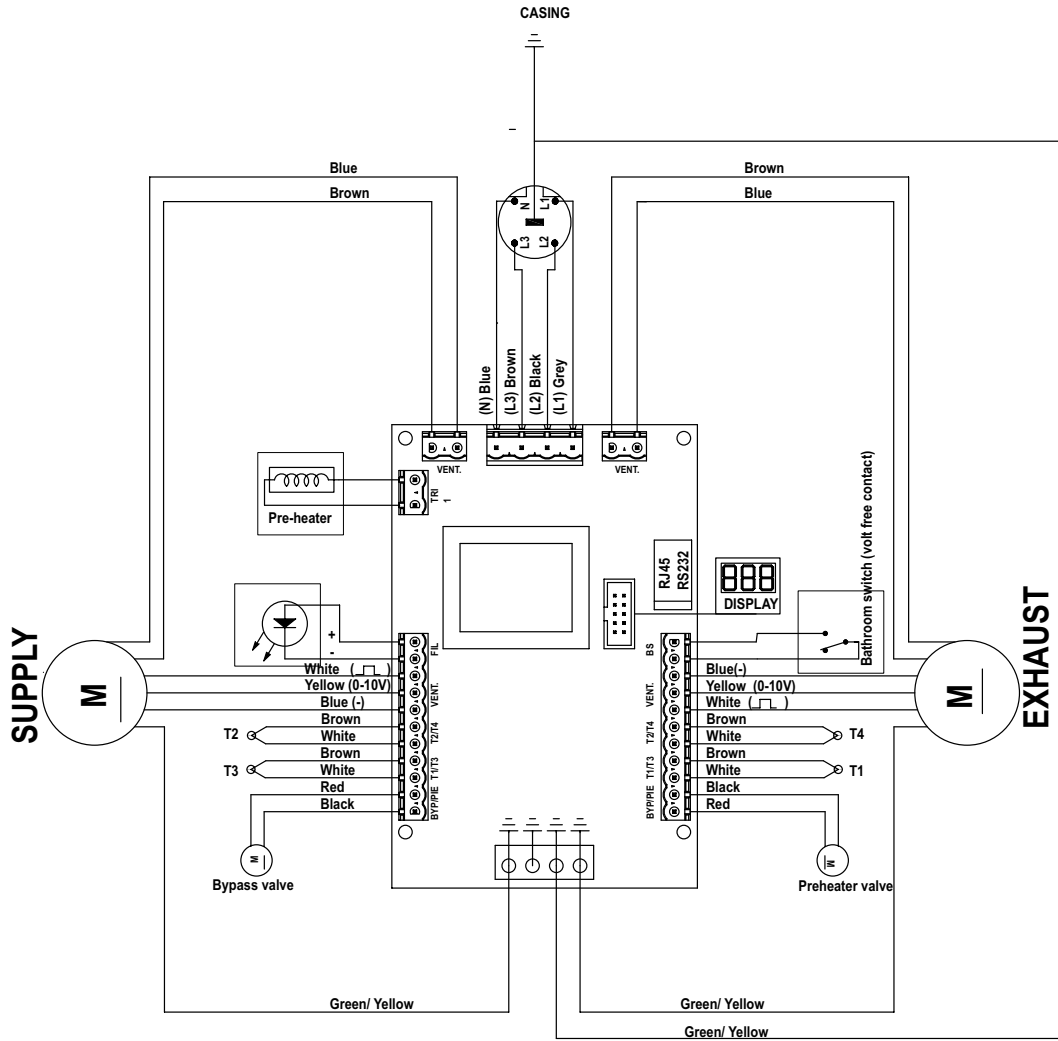

2.14 Wiring diagram: ComfoAir 200 Luxe – LEFT-HAND version

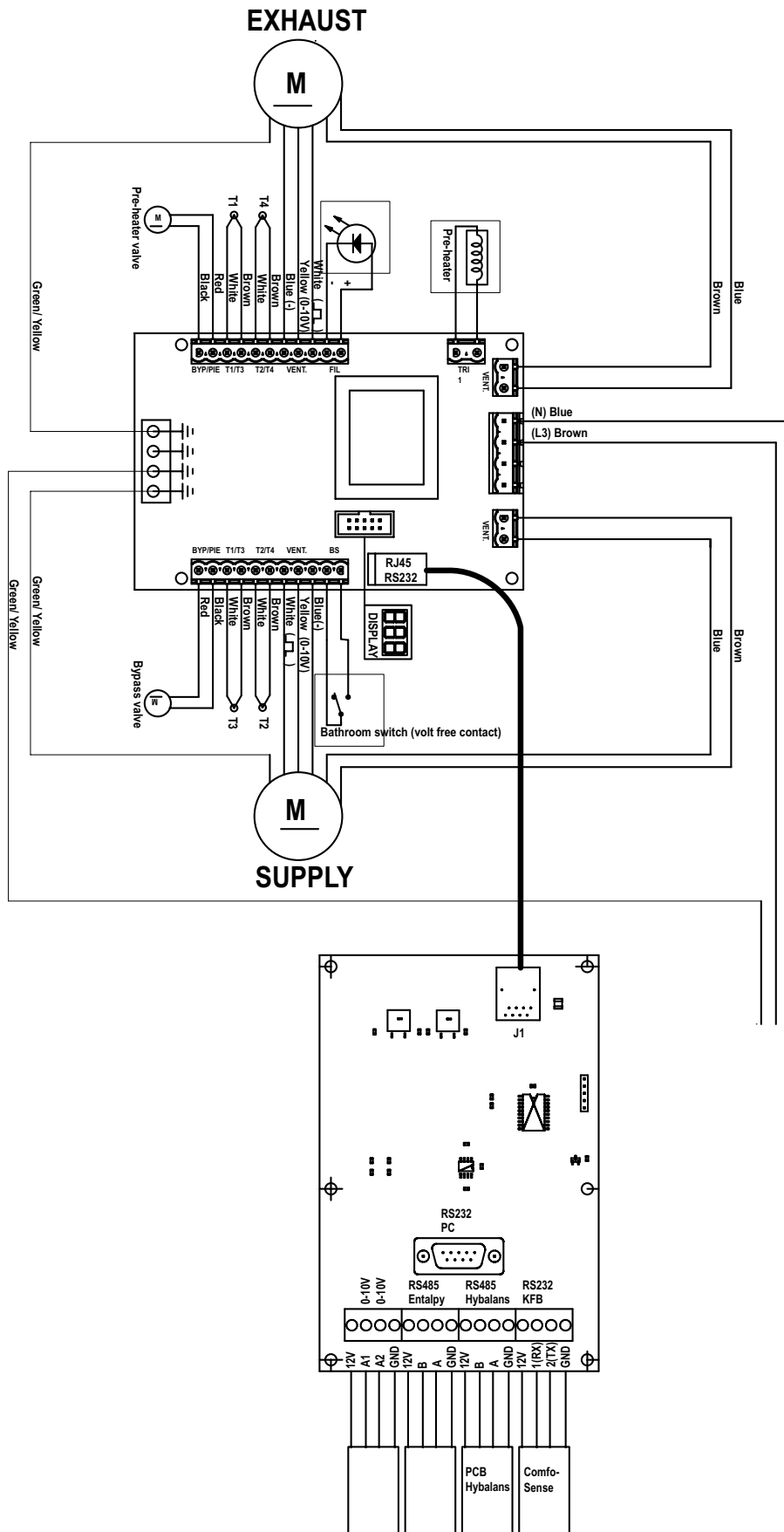

2.15 Wiring diagram: ComfoAir 200 Luxe – RIGHT-HAND version

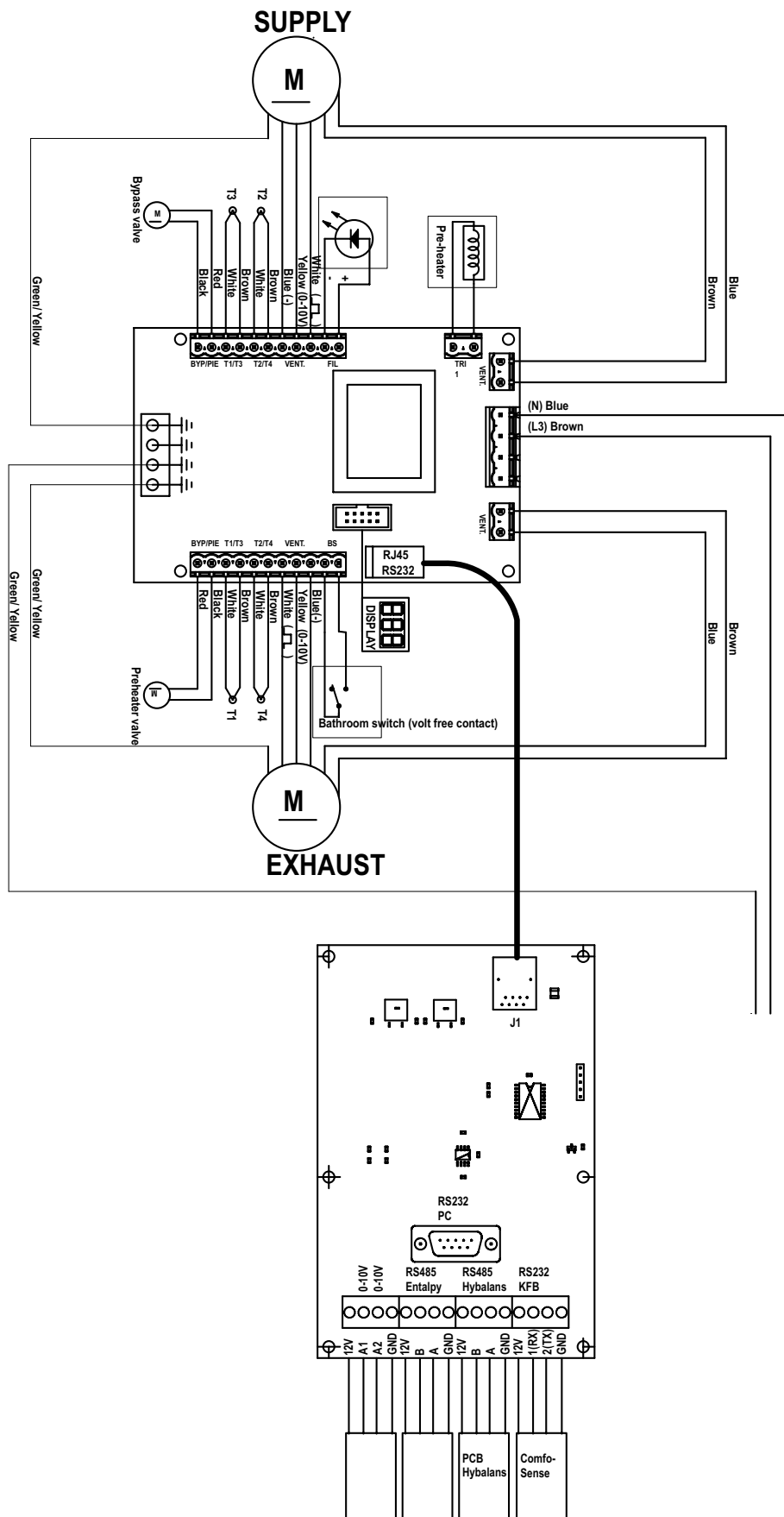

2.16 EEC declaration of conformity

Zehnder Group Nederland B.V.
Lingenstraat 2
8028 PM Zwolle-NL
Tel.: +31 (0)38-4296911
Fax: +31 (0)38-4225694
Company register Zwolle 05022293

EEC declaration of conformity

Machine description : **Heat recovery units: ComfoAir 200 series**

Complies with the following directives : Machinery Directive (2006/42/EEC)
Low Voltage Directive (2006/95/EEC)
EMC Directive (2004/108/EEC)

Zwolle, 15-01-2014
Zehnder Group Nederland B.V.



O. Schulte,
Director Production Zwolle

